



## PRODUCT CONFIGURATION

## OM SERIES MEDIUM CAPACITY (OVAL GEAR METERS)

The FLOMEC® OM Medium Capacity Meters are great for medium flow ranges and have the ability to handle a wide range of fluid viscosities.

### FEATURES / BENEFITS

- High accuracy and repeatability, direct volumetric reading
- Measures high and low viscosity liquids
- Quadrature pulse output option and bi-directional flow
- Optional Exd I/IB approval (ATEX, IECEx)
- No requirement for flow conditioning (straight pipe runs)
- Only two moving parts

### PRODUCT IDENTIFIER **1**

**OM** = Oval Gear Meter

### METER SIZE **2**

- 015** = 1/2" (15 mm), 0.26-10.6 GPM (1-40 L/min)
- 025** = 1" (25 mm), 2.6-40 GPM (10-150 L/min)
- 040** = 1-1/2" (40 mm), 4-66 GPM (15-250 L/min)
- 050** = 2" (50 mm), 8-118 GPM (30-450 L/min) with SS Rotors
- 050** = 2" (50 mm), 8-130 GPM (30-500 L/min) with PPS Rotors

### BODY MATERIAL **3**

- A** = Aluminum
- M** = Intermediate pressure aluminum meter (2000 psi [138 bar] max.) (OM025 only)
- S** = 316L Stainless Steel
- N** = Intermediate Pressure 316L SS (OM015-OM025N = 1450 psi [100 bar]) (OM040N-OM050N = 725 psi / 50 bar)

### ROTOR MATERIAL / BEARING TYPE **4**

- 00** = PPS (not available for 300° F [150° C] meters) / No bearing
- 10** = Keishi cut PPS (for high viscosity liquids) (not available for 300° F [150° C] meters) / No bearing
- 51** = Stainless Steel / Carbon Ceramic
- 71** = Keishi cut Stainless Steel (for high viscosity liquids) / Carbon Ceramic

### O-RING MATERIAL **5**

- 1** = FKM (Viton™) (standard for Alum.) -5° F minimum (-15° C)
- 3** = PTFE encapsulated FKM (Viton™)
- 4** = Buna-N (Nitrile), -40° F minimum (-40° C)

### MAXIMUM TEMPERATURE LIMIT **6**

- 2** = 250° F (120° C) max.
- 3** = 300° F (150° C) max. (Hall Effect) (Includes Stainless Steel terminal cover)
- 5** = 250° F (120° C) max. (includes integral cooling fin)
- 8** = 176° F (80° C) max. (meters with integral instruments)

### PROCESS CONNECTIONS **7**

- 0** = No fittings (Not available on 015 size)
- 1** = BSPP (G) female threaded (ISO 228)
- 2** = NPT female threaded
- 3** = Sanitary Fittings (are 1/2" (13 mm) larger than meter size)
- 4** = ANSI-150 RF Flanged
- 5** = ANSI-300 RF Flanged
- 6** = PN16 DIN Flanged

### CABLE ENTRIES **8**

- 1** = M20 x 1.5 mm (M16 x 1.5 mm for R4 option)
- 2** = 1/2 in. NPT
- 6** = 3 x 16 mm drilled holes (for F instruments only)

### INTEGRAL OPTIONS **9**

- = Combination Reed Switch and Hall Effect Sensor
- SS** = Stainless Steel terminal cover
- RS** = Reed Switch only - to suit Intrinsically safe installations
- E1** = Explosion proof Exd IIB T3...T6 (Aluminum & Stainless meters) [IECEx & ATEX approved]
- E2** = Explosion proof Exd I/IB T3...T6 (stainless meters only) [IECEx & ATEX mines approved]
- QP** = Quadrature pulse (2 NPN phased outputs)
- QPN** = Quadrature pulse (2 NPN phased outputs) with Australian NZNMI approval for trade sale
- Q1** = Explosion proof Exd (with quadrature pulse) [IECEx & ATEX approved]
- Q1N** = Explosion proof Exd (IECEx & ATEX) with Quadrature pulse with Australian NMI & NZ approval for trade sale (Not available on 015 size)
- R3** = Intrinsically safe RT12 with all outputs (GRN housing) [IECEx & ATEX approved]\*#
- R3G** = RT12 Intrinsically Safe rate totalizer with all outputs (GRN Housing) [IECEx & ATEX approved] (with gallons calibration)\*#
- R4** = RT40 rate totalizer with backlit large digit LCD [scalable pulse output, backlight]\*#
- R4G** = RT40 rate totalizer with backlit large digit LCD (Alloy housings with facia) (with gallons calibration)\*#
- R5** = RT14 backlit rate totalizer with all outputs (GRN Housing)\*#
- R5G** = RT14 backlit rate totalizer with all outputs (GRN Housing) (with gallons calibration)\*#
- E0** = EB10 batch controller [2 stage DC batcher & totalizer] (GRN Housing)\*#
- E0G** = EB10 batch controller [2 stage DC batcher & totalizer] (with gallons calibration) (GRN Housing)\*#
- E18** = E018 backlit rate/tot, pulse, 4-20mA, 10 point linearization, HART, aluminium body [IECEx & ATEX approved] (Not available with 015 size)#
- E19** = E018 backlit rate/tot, pulse, 4-20mA, 10 point linearization, HART, stainless steel body [IECEx & ATEX approved] (Not available with 015 size)#
- F18** = F018 backlit rate/tot, pulse, 4-20mA, 10 point linearization, HART#
- F19** = F018 backlit rate/tot, pulse, 4-20mA, 10 point linearization, HART, Intrinsically safe [IECEx & ATEX approved]#
- F31** = Intrinsically safe F130 2 stage batch controller [IECEx & ATEX approved]#

--->>>> **1 2 3 4 5 6 7 8 9**  
**OM 025 A 51 2 -5 2 1 R4**

\*Temp code 5 required for integral instruments between 176oF (80oC) & 250oF (120oC)  
 #Temp code 8 required for integral instruments below 176oF (80oC) by 20%

## SPECIFICATIONS

	OM015	OM025	OM040	OM050
Nominal Size:	1/2" (13 mm)	1" (25 mm)	1 1/2" (38 mm)	2" (51 mm)
*Flow Range:	0.26-10.6 GPM (1-40 L/min)	2.6-40 GPM (10-150 L/min)	4-66 GPM (15-250 L/min)	8-118 GPM (30-450 L/min) (SS) 8-130 GPM (30-500 L/min) (PPS)
Accuracy @3cp:	± 0.5% of reading (accuracy is ± 0.2% of reading with optional RT14 with non-linearity correction)			
Repeatability:	Typically ± 0.03% of reading			
Temperature Range:	-40° F to +300° F (-40° C to +150° C) refer to factory for lower temperature			
<b>Pressure Rating (Threaded Meter):</b>				
Aluminum	990 psi (68 bar)	990 psi (68 bar)	435 psi (30 bar)	285 psi (20 bar)
Intermediate Pressure Aluminum		2000 psi (138 bar)		
316 Stainless Steel	990 psi (68 bar)	990 psi (68 bar)	435 psi (30 bar)	550 psi (38 bar)
Intermediate Pressure SS	1450 psi (100 bar)	1450 psi (100 bar)	725 psi (50 bar)	725 psi (50 bar)

	OM015	OM025	OM040	OM050
<b>Pressure Rating (Mechanical Meter):</b>				
Aluminum	580 psi (40 bar)	580 psi (40 bar)	435 psi (30 bar)	285 psi (20 bar)
316 Stainless Steel	580 psi (40 bar)	580 psi (40 bar)	435 psi (30 bar)	285 psi (20 bar)
Recommended Filtration	100 mesh (150 µm)			
<b>Electrical:</b>				
Output Pulse Resolution:	Pulses / gallon (Pulses / L) - Nominal			
Reed Switch	318 (84)	120 (27)	53 (14)	25 (6.5)
Hall Effect	636 (168)	405 (107)	212 (56)	99 (26)
QP - Quadrature Hall Option	636 (168)	204 (54)	106 (28)	49 (13)
Reed Switch Output	30V (dc) x 200mA max. [maximum thermal shock 180 F (100 C) / minute]			
Hall Effect Output (NPN)	3 wire open collector, 5-24V (dc) max., 20mA max.			
Optional Outputs	4-20mA, scaled pulse, quadrature pulse, flow alarms or two stage batch control			

\*Maximum flow is to be reduced as viscosity increases, see flow de-rating guide.  
Max recommended pressure drop is 14.5 psi (1 bar).

## DIMENSIONS All dimensions are ± .079 (±2 mm)

Modular Fitting	A					
	OM015	OM025A	OM025S/N	OM040	OM050	OM050E
A.N.S.I. 150 DIN16	7.4" (189 mm)	7.8" (198 mm)	9.3" (237 mm)	9.9" (252 mm)	10.9" (277 mm)	10.9" (277 mm)
B.S.P. N.P.T.	4.3" (110 mm)	5.4" (137 mm)	6.9" (176 mm)	7.4" (188 mm)	8.3" (212 mm)	8.3" (212 mm)

Configuration	B							
	OM015A	OM015S/N	OM025A	OM025S/N	OM040A	OM040S/N	OM050	OM050E
EB10 / RT12 / RT14 GRN Housing	6.0" (154 mm)	5.8" (148 mm)	6.6" (168 mm)	6.5" (165 mm)	7.9" (203 mm)	7.6" (194 mm)	8.6" (218 mm)	10.5" (268 mm)
RT40 Alloy Housing	6.2" (157 mm)	5.9" (151 mm)	6.7" (171 mm)	6.6" (168 mm)	8.1" (206 mm)	7.8" (197 mm)	8.7" (221 mm)	10.7" (271 mm)
Cover	4.2" (106 mm)	3.9" (100 mm)	4.7" (123 mm)	4.6" (117 mm)	6.1" (155 mm)	5.7" (146 mm)	6.7" (170 mm)	8.6" (220 mm)

## APPLICATIONS

- Oils
- Fuel
- Diesel
- Truck Metering
- Bunker C Fuel Oil
- Chemical Additive Injection
- Batching
- Molasses
- Clean Fluids
- Oil-Based Paints
- Industrial Fluids
- Chemical Feed Lines

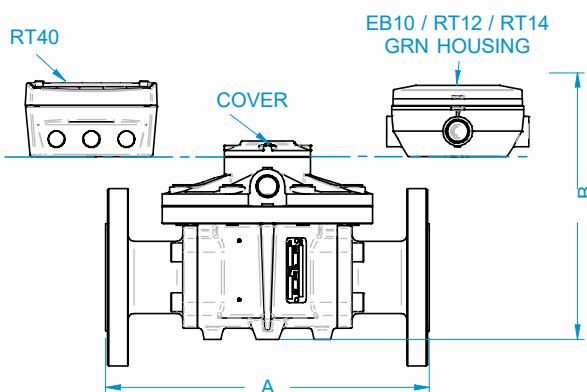

OM040: Ø6.3" (160 mm)  
OM050: Ø7.1" (180 mm)  
OM015: Ø4.3" (110 mm)  
OM025: Ø4.7" (120 mm)

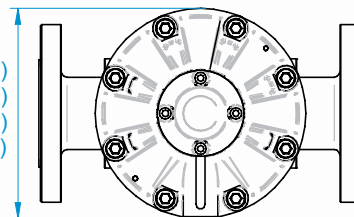

## APPROVALS



NEMA  
4X

IP66/67

**B.E.S.**  
**FLOWMETERS**

P: 03 5956 8685 M: 0488 029 256  
Email: sales@besflowmeters.com.au