

Commercial Grade **TURBINE HOUSING** Owner's Manual

Includes Aluminum and Nylon

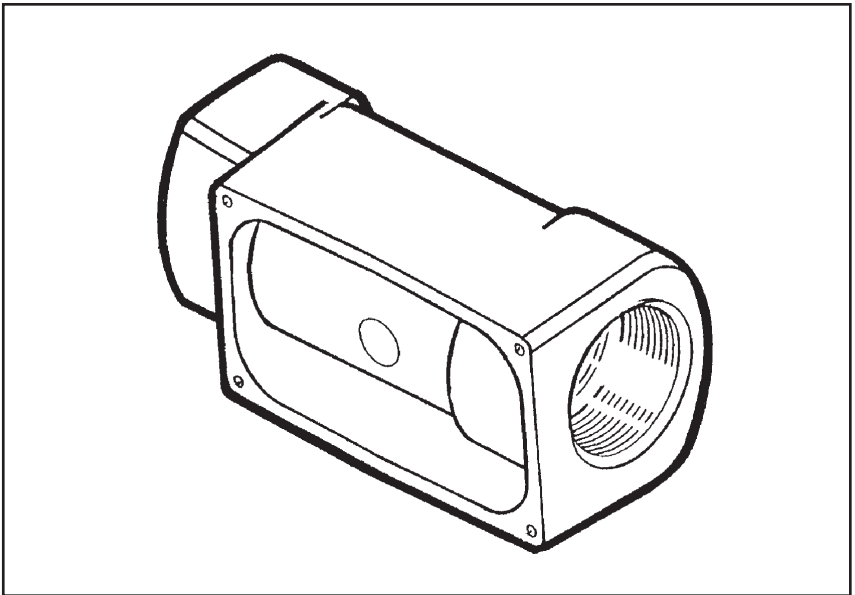

To the owner...

Congratulations on receiving your GPI Commercial Grade Turbine. We are pleased to provide you with a product designed to give you maximum reliability and efficiency.

Our business is the design, manufacture, and marketing of liquid handling, agricultural, and recreational products. We succeed because we provide customers with innovative, reliable, safe, timely, and competitively-priced products. We pride ourselves in conducting our business with integrity and professionalism.

We are proud to provide you with a quality product and the support you need to obtain years of safe, dependable service.



Victor Lukic, President
Great Plains Industries, Inc.

GENERAL INFORMATION

This manual will assist you in installing and maintaining your GPI Commercial Grade turbine housing. (See Figure 1) Information on computer electronics and accessory modules are contained in other manuals. Please reference those as necessary.

Figure 1

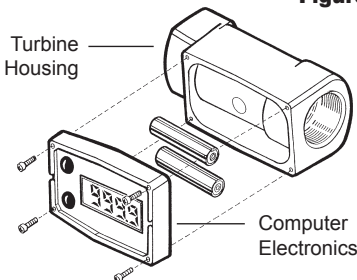

TABLE OF CONTENTS

General Information.....	2
Installation	4
Maintenance	5
Troubleshooting.....	6
Specifications	7
Aluminum	7
Nylon.....	9
Parts	11
Service.....	11

For best results, take the time to fully acquaint yourself with all information about all components of your GPI Electronic Digital Metering System prior to installation and use. If you need assistance, contact the distributor from whom you purchased your turbine.



This symbol is used throughout the manual to call your attention to safety messages.



Warnings alert you to the potential for personal injury.



Cautions call your attention to practices or procedures which may damage your equipment.

Notes give information that can improve efficiency of operations.

It is your responsibility to make sure that all operators have access to adequate instructions about safe operating and maintenance procedures.

Read Me!

For your safety, review the major warnings and cautions below before operating your equipment.

⚠ WARNING

The apparatus enclosure may contain aluminum and is considered to constitute a potential risk of ignition by impact or friction. Care must be taken into account during installation and use to prevent impact or friction.

⚠ WARNING

Part of the enclosure is constructed from plastic. To prevent the risk of electrostatic sparking the plastic surface should only be cleaned with a damp cloth.

1. This equipment is approved to handle only fluids that are compatible with the housing material. Use only fluids that are compatible with the wetted components of your turbine.
2. When measuring flammable liquids, observe precautions against fire or explosion.
3. When handling hazardous liquids, always follow the liquid manufacturer's safety precautions.
4. When working in hazardous environments, always exercise appropriate safety precautions.
5. Always dispose of used cleaning solvents in a safe manner according to the solvent manufacturer's instructions.

6. During turbine removal, liquid may spill. Follow the liquid manufacturer's safety precautions for clean up of minor spills.

7. Do not blow compressed air through the turbine.

8. Do not allow liquids to dry inside the turbine.

9. Handle the rotor carefully. Even small scratches or nicks can affect accuracy.

10. When tightening the turbine, use a wrench only on the wrench flats.

11. For best results, always verify accuracy before use.

Product Description

GPI Commercial Meter Turbines are identified by the internal diameter and the inlet and outlet.

Model 025 – 1 inch (Low Flow)

Model 100 – 1 inch (Mid Flow)

Model 200 – 2 inch (High Flow)

Each of these turbines is designed to work with on-board computer electronics and/or with one of several accessory modules that can interface to a wide variety of reporting and collecting devices.

Liquids flow through the turbine housing causing an internal rotor to spin. As the rotor spins, an electrical signal is generated in the pickup coil. The electrical signal provides the output necessary to operate the on-board computer electronics for local indication directly on the turbine or one of several accessory modules that transmit the signal to external equipment.

Upon receipt, examine your meter for visible damage. The turbine is a precision measuring instrument and should be handled as such. Remove the protective plugs and caps for a thorough inspection. If any items are damaged or missing, contact your distributor.

Make sure the turbine model meets your specific needs. Refer to the Specifications Section and confirm the following:

1. The flowrate is within the limits of your model.
2. The liquid is compatible with the turbine's wetted components.
3. The system's pressure does not exceed the turbine's maximum pressure rating.

Information specific to your particular turbine, including serial number and manufacturing date is printed on the bottom of the turbine.

For your future reference, it might be useful to record this information in the manual in case it becomes unreadable on the turbine.

INSTALLATION

All GPI turbines are designed to measure flow in only one direction. The direction is indicated by the arrow cast-molded in the turbine outlet. If the opposite direction is desired, and you are using on-board computer electronics, rotate the computer electronics 180 degrees prior to installation.

Flow altering devices such as elbows, valves, and reducers can affect accuracy. The following recommended guidelines are given to enhance accuracy and maximize performance. Distances given here are minimum requirements; double them for desired straight pipe lengths.

Upstream from the turbine, allow a minimum straight pipe length at least 20 times the internal diameter of the turbine. For example, with the 1-inch turbine, there should be 20 inches (51 cm) of straight pipe immediately upstream.

Downstream from the turbine, allow a minimum straight pipe length at least 5 times the internal diameter of your turbine. For example, with the 1-inch turbine, there should be 5 inches (12.7 cm) of straight pipe immediately downstream. The desired downstream distance is 10 inches (25.4 cm).

A typical back pressure of 5 to 50 PSI (0.34 to 3.4 bar) will prevent cavitation. Create back pressure by installing a control valve on the downstream side of the meter at the proper distance detailed above.

Foreign material in the liquid being measured can clog the turbine's rotor and adversely affect accuracy. If this problem is anticipated or experienced, install screens to filter impurities from incoming liquids.

Model 025:

Maximum Particulate Size	
Inches:	0.005
Microns:	125
Mesh:	120

Models 100 and 200:

Maximum Particulate Size	
Inches:	0.018
Microns:	500
Mesh:	35

All GPI turbines are tested and calibrated at the factory using state-of-the-art calibration procedures and test equipment.

To ensure accurate measurement, remove all air from the system before use. To purge the system of air:

1. Ensure some back pressure exists on the turbine in the line.
2. Open the discharge valve or nozzle and allow fluid to completely fill the system. Make sure the stream is full and steady.
3. Close the discharge valve or nozzle.
4. Start normal operations.

Connections

1. To protect against leakage, seal all threads with an appropriate sealing compound. Make sure the sealing compound does not intrude into the flow path.
2. Make sure the arrow on the outlet is pointed in the direction of the flow.

⚠ CAUTION

Using a wrench on plastic meters could damage the meter.

3. Tighten the turbine onto the fittings. Use a wrench only on wrench flats.

NOTE: If connecting to new male threads, burrs and curls can adversely effect accuracy. Correct the problem prior to turbine installation.

It is strongly recommended that accuracy be verified prior to use.

MAINTENANCE

Verify Accuracy

Before use, check the turbine's accuracy and verify calibration.

1. Make sure there is no air in the system.
2. Measure an exact known volume into an accurate container.
3. Verify the volume against the readout or recording equipment.

NOTE: If necessary, use a correction factor to figure final volume.

For best results, accuracy should be verified periodically as part of a routine maintenance schedule.

Remove the Turbine

⚠ WARNING

During turbine removal, liquid may spill. Follow the liquid manufacturer's safety precautions for clean up of minor spills.

1. Drain all liquid from the turbine. Wear protective clothing as necessary.
2. Loosen both ends of the turbine. Use a wrench only on the turbine's wrench flats.
3. If the turbine is not immediately installed again, cap lines as necessary.

Clean the Turbine

During use, the turbine should be kept full of liquid to ensure that drying does not occur inside the turbine. If drying or caking should occur, the rotor will stick or drag, affecting accuracy. To determine if the rotor is stuck or dragging, gently blow air through the meter and listen for the quiet whir of the rotor.

⚠ CAUTION

Never blow compressed air through the meter. It could damage the rotor.

1. Remove the turbine from the system following the directions above.
2. Apply a penetrating lubricant such as WD-40® or a recommended cleaning solvent on the turbine's rotor, shaft, and bearings. Allow it to soak for 10 to 15 minutes.

⚠ CAUTION

Do not submerge the meter.

3. Carefully remove residue from the rotor using a soft bursh or small probe such as a screw-driver. Be careful not to damage the rotor and support.
4. When the rotor turns freely, install it again following the installation instructions given earlier in this manual.

⚠ WARNING

Follow the liquid manufacturer's instructions for the disposal of contaminated cleaning solvents.

TROUBLESHOOTING

Symptom	Probable Cause	Solution
A. MEASUREMENT IS NOT ACCU-RATE	1. Turbine operated below minimum rate	Increase flowrate. See Specifications.
	2. Turbine partially clogged with dried liquid	Remove turbine. Clean carefully. Make sure rotor spins freely.
	3. Turbine bearings partially clogged with dried liquid	Remove turbine. Clean carefully. Make sure rotor spins freely.
	4. Sealant wrapped around rotor	Remove turbine. Clear material from rotor. Make sure rotor spins freely.
	5. Installed too close to fittings	Install correctly. See Installation Section.
	6. Improper connections to recording device	Check all electrical connections. Reference appropriate installation instructions.
	7. Accuracy needs verification	Complete normal accuracy verification procedures. Repeat periodically.

SPECIFICATIONS

Aluminum

All data on Models A025 and A100 determined with 1 centipoise Kermac solvent test fluid at 70° F (21° C). Data on Model A200 is determined with water at 70° F (21° C).

Models Size	A025 1 inch Low Flow	A100 1 inch	A200 2 inch
Linear Flow Range Gallons/minute (GPM) Litres/minute (LPM)	0.3-3 1-11	3-50 11-190	30-300 114-1,135
Maximum Flow Gallons/minute (GPM) Litres/minute (LPM)	3 11	50 190	300 1,135
Maximum Pressure Drop in 10:1 Range PSIG bar	8 0.55	5 0.34	4 0.28
Frequency Range in Flow Range	11-110 Hz @ 0.3-3 GPM	36.5-608.3 Hz @ 3-50 GPM	36-360 Hz @ 30-300 GPM
Connections NPT or ISO Threads Female Inlet/Outlet Size	Yes Yes 1 in.	Yes Yes 1 in.	Yes Yes 2 in.
Weight with Computer Electronics Pounds Kilograms	1.35 lbs. .61 kg	1.35 lbs. .61 kg	3.0 lbs. 1.36 kg

Performance

Linear Range for 1 in. Low Flow: N/A*
 Linear Range for 1 in.: ± 1.5% of reading
 Linear Range for 2 in.: ± 1.5% of reading
 Repeatability for 1 in. Low Flow: ± 1%
 Repeatability for 1 in.: ± 0.2%
 Repeatability for 2 in.: ± 0.2%

Pressure Rating 300 PSIG (21 bar)

Wetted Components

Housing: Aluminum
 Journal Bearings: Ceramic (96% Alumina)
 Shaft: Tungsten Carbide
 Rotor and Supports: Nylon
 Retaining Rings: 316 Stainless Steel

Temperature Range -40° F to +250°F (-40° C to +121° C)

These temperatures apply to operations and storage. They are only for the turbine without computer electronics. Final operational temperature range is determined by computer electronics or accessory modules.

* Accuracy can vary up to ±5% depending on installation and fluid type. Field calibration is recommended for best accuracy.

Aluminum cont'd.

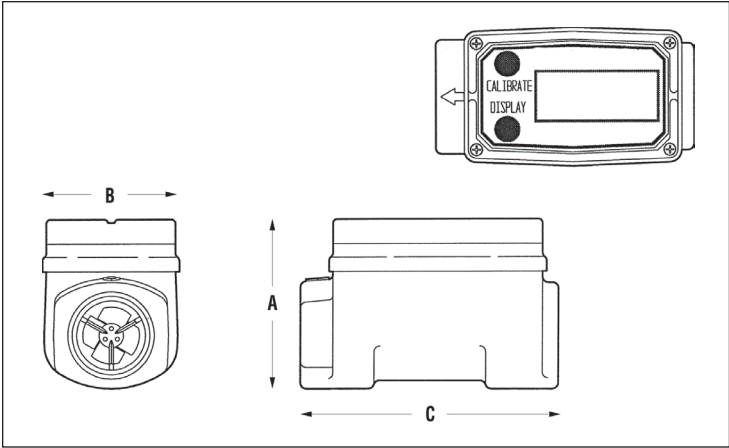

Dimensions

Models Size	A025 1 inch Low Flow	A100 1 inch	A200 2 inch
A = Height†: Inches Centimeters	2.5 in. 6.3 cm	2.5 in. 6.3 cm	4.25 in. 11.4 cm
B = Width Inches Centimeters	2.0 in. 5.1 cm	2.0 in. 5.1 cm	3.0 in. 7.6 cm
C = Length Inches Centimeters	4.0 in. 10.1 cm	4.0 in. 10.1 cm	6.0 in. 15.2 cm

† Height includes 0.7 inch (1.8 cm) for the computer electronics.

SPECIFICATIONS

Nylon

All data on Models N025 and N100 determined with 1 centipoise Kermac solvent test fluid at 70° F (21° C).

Models Size	N025 1 inch Low Flow	N100 1 inch
Linear Flow Range Gallons/minute (GPM) Litres/minute (LPM)	0.3 - 3 1 - 11	3 - 50 11 - 190
Maximum Flow Gallons/minute (GPM) Litres/minute (LPM)	3 11	50 190
Maximum Pressure Drop in 10:1 Range PSIG bar	8 0.55	5 0.34
Frequency Range in Flow Range	11 - 110 Hz @ 0.3 - 3 GPM	36.5 - 608.3 Hz @ 3 - 50 GPM
Connections NPT or ISO Threads Female Inlet/Outlet Size	Yes Yes 1 in.	Yes Yes 1 in.
Weight with Computer Electronics Pounds Kilograms	1.0 lbs. 0.5 kg	1.0 lbs. 0.5 kg

Performance

Linear Range for 1 in. Low Flow: N/A*
 Linear Range for 1 in.: ± 1.5% of reading
 Repeatability for 1 in. Low Flow: ± 1%
 Repeatability for 1 in.: ± 0.2%

Pressure Rating

150 PSIG (10.3 bar)

Wetted Components

Housing: Nylon
 Journal Bearings: Ceramic
 Shaft: Tungsten Carbide
 Rotor and Supports: Nylon
 Retaining Rings: 316 Stainless Steel

Temperature Range

+14° F to +250° F (-40° C to +121° C)

These temperatures apply to operations and storage. They are only for the turbine without computer electronics. Final operational temperature range is determined by computer electronics or accessory modules.

* Accuracy can vary up to ±5% depending on installation and fluid type. Field calibration is recommended for best accuracy.

Nylon cont'd.

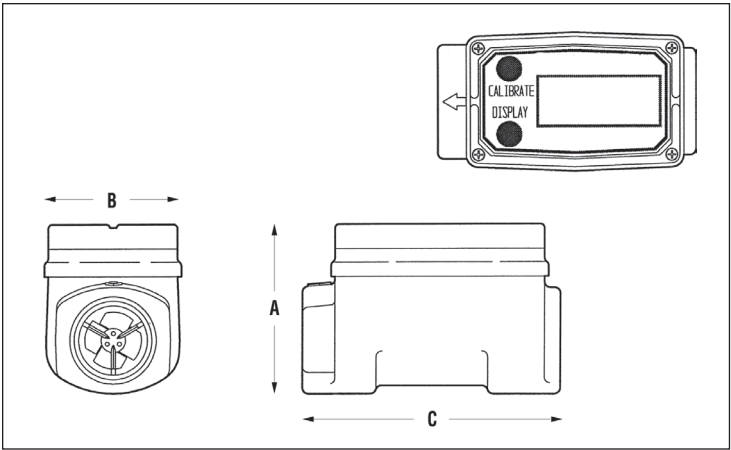

Dimensions

Models Size	N025 1 inch Low Flow	N100 1 inch
A = Height* Inches Centimeters	2.5 in. 6.3 cm	2.5 in. 6.3 cm
B = Width Inches Centimeters	2.0 in. 5.1 cm	2.0 in. 5.1 cm
C = Length Inches Centimeters	4.0 in. 10.1 cm	4.0 in. 10.1 cm

* Height includes 0.7 inch (1.8 cm) for the computer electronics.

PARTS

Order Replacement Kits with the part numbers given here.

Part No.	Description
906004-85	EDM Cover Single Access Port (optional)
906004-86	EDM Cover Dual Access Port (optional)
904004-12	Screw, Aluminum Meter
904003-88	Screw, Nylon Meter
113520-1	Battery Kit (2 batteries included)
901002-52	Seal, Computer

SERVICE

For warranty consideration, parts, or other service information, please contact your local distributor. If you need further assistance, call the GPI Customer Service Department in Wichita, Kansas, during normal business hours.

1-888-996-3837

To obtain prompt, efficient service, always be prepared with the following information:

1. The model number of your turbine.
2. The serial number or manufacturing date code of your turbine.
3. Specific information about part numbers and descriptions.

For warranty work always be prepared with your original sales slip or other evidence of purchase date.

Returning Parts

Please contact the factory before returning any parts. It may be possible to diagnose the trouble and identify needed parts in a telephone call. GPI can also inform you of any special handling requirements you will need to follow covering the transportation and handling of equipment which has been used to transfer hazardous or flammable liquids.

⚠ CAUTION

Do not return turbines without specific authority from the GPI Customer Service Department. Due to strict regulations governing transportation, handling, and disposal of hazardous or flammable liquids, GPI will not accept turbines for rework unless they are completely free of liquid residue.

⚠ CAUTION

Turbines not flushed before shipment can be refused and returned to the sender.

Limited Warranty Policy

Great Plains Industries, Inc. 5252 E. 36th Street North, Wichita, KS USA 67220-3205, hereby provides a limited warranty against defects in material and workmanship on all products manufactured by Great Plains Industries, Inc. This product includes a 1 year warranty. Manufacturer's sole obligation under the foregoing warranties will be limited to either, at Manufacturer's option, replacing or repairing defective Goods (subject to limitations hereinafter provided) or refunding the purchase price for such Goods theretofore paid by the Buyer, and Buyer's exclusive remedy for breach of any such warranties will be enforcement of such obligations of Manufacturer. The warranty shall extend to the purchaser of this product and to any person to whom such product is transferred during the warranty period.

The warranty period shall begin on the date of manufacture or on the date of purchase with an original sales receipt. This warranty shall not apply if:

- A. the product has been altered or modified outside the warrantor's duly appointed representative;
- B. the product has been subjected to neglect, misuse, abuse or damage or has been installed or operated other than in accordance with the manufacturer's operating instructions.

To make a claim against this warranty, contact the GPI Customer Service Department at 316-686-7361 or 888-996-3837. Or by mail at:

Great Plains Industries, Inc.
5252 E. 36th St. North
Wichita, KS, USA 67220-3205

If you are outside North or South America contact:

Great Plains Industries – Australia
1/16 Atkinson Road,
Taren Point NSW 2229, Sydney, Australia

The company shall, notify the customer to either send the product, transportation prepaid, to the company at its office in Wichita, Kansas, or to a duly authorized service center. The company shall perform all obligations imposed on it by the terms of this warranty within 60 days of receipt of the defective product.

GREAT PLAINS INDUSTRIES, INC., EXCLUDES LIABILITY UNDER THIS WARRANTY FOR DIRECT, INDIRECT, INCIDENTAL AND CONSEQUENTIAL DAMAGES INCURRED IN THE USE OR LOSS OF USE OF THE PRODUCT WARRANTED HEREUNDER.

The company herewith expressly disclaims any warranty of merchantability or fitness for any particular purpose other than for which it was designed.

This warranty gives you specific rights and you may also have other rights which vary from U.S. state to U.S. state.

Note: In compliance with MAGNUSON MOSS CONSUMER WARRANTY ACT – Part 702 (governs the resale availability of the warranty terms).



IECEX



ATEX

NEMA
4

(IP65)

Wichita · Sydney · Mexico City

GREAT PLAINS INDUSTRIES



Great Plains Industries, Inc. / 888-996-3837 / GPI.net