



Electromagnetic Flowmeter compact for conductivity liquids



measuring
•
monitoring
•
analysing

MIK



MIK with
frequency-, switching-, analogue output



MIK with
digital plug on display



MIK with
dosing electronic



MIK with
compact electronic

- Range from liquids, acids and caustic solutions:
0.01-0.5 ... 35-700 l/min
- Accuracy: $\pm 2.0\%$ of full scale
- p_{\max} : 10 bar; t_{\max} : 80 °C
- Connection: G $\frac{1}{2}$... G 2 $\frac{3}{4}$ male, diverse accessories
- Material:
normal liquids: PPS, stainless steel
aggressive liquids:
PVDF, Hastelloy® or Tantalum
- Advantage:
 - no moving parts in the measuring tube
 - low pressure loss
 - any mounting position
 - short reaction time – replacement for calorimetric flow switch
 - high quality for lowest price

GS



KOBOLD companies worldwide:

AUSTRALIA, AUSTRIA, BELGIUM, BULGARIA, CANADA, CHINA, CZECHIA, EGYPT, FRANCE, GERMANY, GREAT BRITAIN, HUNGARY, INDIA, INDONESIA, ITALY, MALAYSIA, MEXICO, NETHERLANDS, PERU, POLAND, REPUBLIC OF KOREA, ROMANIA, RUSSIA, SPAIN, SWITZERLAND, THAILAND, TUNISIA, TURKEY, USA, VIETNAM

KOBOLD Messring GmbH
Nordring 22-24
D-65719 Hofheim/Ts.
Head Office:
+49(0)6192 299-0
+49(0)6192 23398
info.de@kobold.com
www.kobold.com



Description

The new KOBOLD flow meter Type MIK is used for measuring and monitoring smaller and medium-sized flow of conductivity liquids in pipes.

The device operates according to the electromagnetic measurement principle. According to Faraday's Law of magnetic induction a voltage is induced in a conductor moving through a magnetic field. The electrically conductive measuring agent acts as the moved conductor. The voltage induced in the measuring agent is proportional to the flow velocity and is therefore a value for the volumetric flow. The flowing media must have a minimum conductivity. The induced voltage is picked up by two sensing electrodes which are in contact with the measuring agent and sent to the measuring amplifier. The flow rate will be calculated based on the cross sectional area of the pipe.

The measurement is not depending on the process liquid and its material properties such as density, viscosity and temperature. The device may be equipped with a switch, frequency or analogue output. Moreover, there is a compact electronic system to be selected from, which contains a switch and an analogue output.

The device series is completed by an optionally obtainable dosing and counter electronic system. The counter electronics system shows the current flow rate on the first line of the display and shows the partial or overall volume on the second line. A dosing electronic system controls simple filling duties and also measures the flow rate, overall volume and filling volume. The analogue output and two relay outputs can be utilised for the further processing of signals.

Media

- Electric conductivity liquids
- Acids and caustic solutions
- Drinking, cooling and waste water
- Ground water, raw water
- Aggressive or salty solution
- Unsuitable for oil (missing conductivity)

Areas of Application

Flow monitoring, flow measuring, dosing and counting for

- Machine building
- Chemical Industry
- Paper Industry
- Automobile Industry
- Cement Industry
- Laboratory

Technical Details

Range: see table
 Accuracy: ±2.0% of full scale
 Repeat accuracy: ±1.0% of full scale
 Measurement process: electromagnetic
 Electrical conductivity: min. 30 µS/cm (at MIK- ...08 and 10: min. 200 µS/cm)
 Mounting position: in all directions, flow in direction of the arrow
 In-/Outlet: 3 x DN / 2 x DN
 Media temperature: -20...+80 °C (max. +60 °C with PVC-connection set)
 Ambient temperature: -10...+60 °C
 Max. pressure: 10 bar
 Max. pressure loss: max. 250 mbar at full scale
 Max. medium viscosity: 20 cSt ≤ G1;
 70 cSt ≥ G1½

Wetted Parts

Sensor housing: PPS or PVDF, fibreglass-reinforced
 Connection set: PVC-gluе connection or hose connection, weld-on ends stainless steel 1.4404
 Electrodes: stainless steel 1.4404, Hastelloy® C4 or Tantalum
 Seal: NBR, FPM or FFKM
 Response time t_{90} : approximately 1 s (at flow changes >10% FS)
 Protection: IP65

Connection/Ranges

Connection	Inside diameter	Flow velocity at full scale	Range
G ½ male	5 mm	approx. 0.45 m/s	10...500ml/min
		approx. 0.9 m/s	0.05...1.0l/min
		approx. 2.7 m/s	0.16...3.2l/min
G ¾ male	10 mm	approx. 2.2 m/s	0.5...10.0l/min
		approx. 3.5 m/s	0.8...16.0l/min
G 1 male	15 mm	approx. 3.0 m/s	1.6...32.0l/min
		approx. 4.7 m/s	2.5...50l/min
G 1½ male	20 mm	approx. 3.3 m/s	3.2...63l/min
		approx. 5.3 m/s	5.0...100l/min
G 2 male	32 mm	approx. 3.3 m/s	8...160l/min
		approx. 6.6 m/s	16...320l/min
G 2¾ male	54 mm	approx. 3.6 m/s	25...500l/min
		approx. 5.1 m/s	35...700l/min



MIK-...F300, MIK-...F390

Impulse output: PNP, Open Collector, max. 200 mA
500 Hz at full scale (...F300)
50...1000 Hz at full scale (...F390)
factory set as per customer request

Power supply: 24 V_{DC} ±20 %

Power consumption: 60 mA

Electrical connection: plug M 12 x 1

MIK-...S300, MIK-...S30D

Display: duo-LED for switch status

Switching output: relay SPDT, max. 1A/30V_{DC}
or aktive 24 V_{DC}, N/C / N/O

Switch point: 10...100% of full scale in
10%-steps that can be configured
by the customer using a rotary
switch

Power supply: 24 V_{DC} ±20 %

Power consumption: 80 mA

Electrical connection: plug M 12 x 1.5-pin

MIK-...L303; MIK-...L343

Output: 0(4)-20 mA, 3-wire

Max. load: 500 Ω

Power supply: 24 V_{DC} ±20%

Power consumption: 80 mA

Electrical connection: plug M 12 x 1

MIK-...L443 (usage with AUF-3000)

Output: 4-20 mA, 3-wire

Max. load: 500 Ω

Power supply: 24 V_{DC} ±20%

Power consumption: 80 mA

Electrical connection: plug DIN 43650

MIK-...C3xx (Compact electronics)

Display: 3-digit LED

Analogue output: (0)4...20 mA adjustable
(only MIK-...C34x)

Max. load: 500 Ω

Switching output: 1(2) semiconductor PNP or NPN,
set at factory

Contact function: N/C / N/O-frequency
programmable

Settings: via 2 buttons

Power supply: 24 V_{DC} ±20 %, 3-wire

Power consumption: 120 mA

Electrical connection: plug M 12 x 1

MIK-...Exxx (Counter electronics)

Display: LCD, 2 x 8 digit, illuminated
total, part and flow quantities,
units selectable

Quantity meter: 8-digit

Analogue output: (0)4...20 mA adjustable

Load: max. 500 Ω

Switching output: 2 relays, max. 30 V_{AC/DC}/2 A/60 VA
via 4 buttons

Settings: reset, MIN/MAX memory,
flow monitor, monitoring for part
and total quantity, language

Power supply: 24 V_{DC} ±20 %, 3-wire

Power consumption: approx. 150 mA

Electrical connections: cable connection or M 12 plug

More technical details see data sheet ZED

MIK-...Gxxx (Dosing electronics)

Display: LCD, 2 x 8 digit, illuminated
dosing-, total-, and flow quantity,
units selectable

Quantity meter: 8-digit

Dosage: 5-digit

Analogue output: (0)4...20 mA adjustable

Load: max. 500 Ω

Switching output: 2 relays, max. 30 V_{AC/DC}/2 A/60 VA
via 4 buttons

Settings: dosing (relay S2), start, stop,
reset, fine dosing,
correction amount, flow switch,
total quantity, language

Power supply: 24 V_{DC} ±20 %, 3-wire

Power consumption: approx. 150 mA

Electrical connection: cable connection or M 12 plug

More technical details see data sheet ZED

Electrical Connections

MIK-...S300

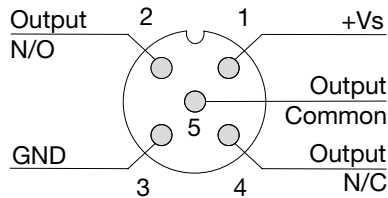

MIK-...S30D

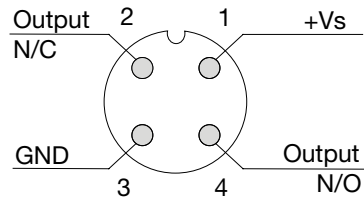

MIK-...L3x3, MIK-...F3x0

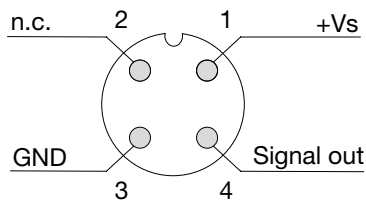

MIK-...L443

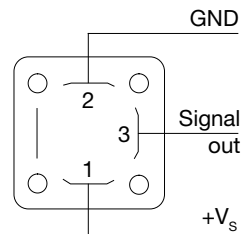

MIK-...C30*

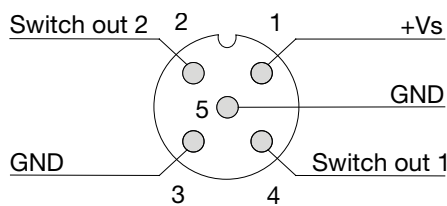

MIK-...C34*

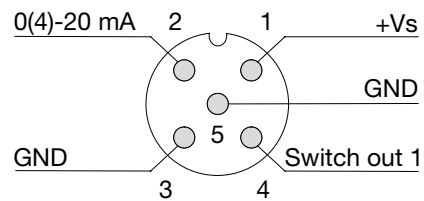

MIK-...E14R, MIK-...G14 Cable Connection

Wire number	MIK-...E14R Counter electronics	MIK-...G14R Dosing electronics
1	+24 V _{DC}	+24 V _{DC}
2	GND	GND
3	4-20 mA	4-20 mA
4	GND	GND
5	n.c.	Control 1*
6	Reset part quantity	Control 2*
7	Relay S1	Relay S1
8	Relay S1	Relay S1
9	Relay S2	Relay S2
10	Relay S2	Relay S2

Control 1 <-> GND: Start-Dosing
 Control 2 <-> GND: Stop-Dosing
 Control 1 <-> Control 2: Reset-Dosing

Plug Connection

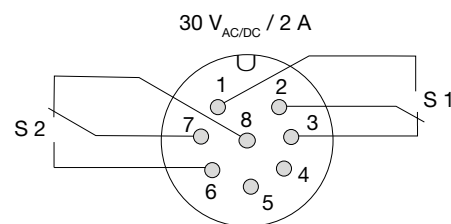
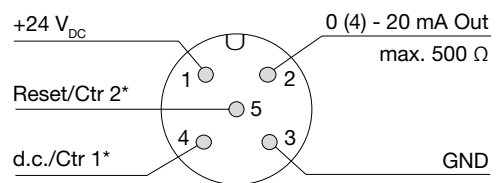



Order Details (Example: MIK-5NA 10 A F300)

Model	Range	Connection set	Electronics
MIK-5NA.. = PPS-housing, NBR-seal, stainless steel- electrode MIK-5VA.. = PPS-housing, FPM-seal, stainless steel- electrode MIK-5NC.. = PPS-housing, NBR-seal, Hastelloy®- electrode MIK-5VC.. = PPS-housing, FPM-seal, Hastelloy®- electrode MIK-6FC.. = PVDF-housing, FFKM-seal, Hastelloy®- electrode MIK-6FT.. = PVDF-housing, FFKM-seal, Tantalum- electrode	..08.. = 10...500 l/min, G ½ ..10.. = 0.05...1.0 l/min, G ½ ..15.. = 0.16...3.2 l/min, G ½	..A.. = without ¹⁾ ..P.. = PVC-hose connection ..E.. = stainless steel- weld-on ends	Frequency output ..F300 = M12-plug, 500 Hz ..F390 = M12-plug, 50...1000 Hz ²⁾ Switching output ..S300 = relay, M12-plug ..S30D = aktive 24 V _{DC} , M12-plug Analogue output ..L303 = M12-plug, 0 - 20 mA ..L343 = M12-plug, 4 - 20 mA ..L443 = DIN-plug, 4 - 20 mA Compact electronics⁴⁾ ..C30R = 2 x Open Coll. PNP ..C30M = 2 x Open Coll. NPN ..C34P = 0(4) - 20 mA, 1 x Open Coll. PNP ..C34N = 0(4) - 20 mA, 1 x Open Coll. NPN Counter electronics ..E14R = LCD, 0(4)-20 mA, 2 x relay, 1.5 m cable ..E34R = LCD, 0(4)-20 mA, 2 x relay, M12 plug ..E94R = LCD, 0(4)-20 mA, 2 x relay, cable >1.5 m ³⁾ Dosing electronics ..G14R = LCD, 0(4)-20 mA, 2 x relay, 1.5 m cable ..G34R = LCD, 0(4)-20 mA, 2 x relay, M12 plug ..G94R = LCD, 0(4)-20 mA, 2 x relay, cable >1.5 m ³⁾
	..20.. = 0.5...10.0 l/min, G ¾ ..25.. = 0.8...16.0 l/min, G ¾	..A.. = without ¹⁾ ..K.. = PVC-glue connection ..P.. = PVC-hose connection ..E.. = stainless steel- weld-on ends	
	..30.. = 1.6...32.0 l/min, G 1 ..35.. = 2.5...50.0 l/min, G 1	..A.. = without ¹⁾ ..K.. = PVC-glue connection ..E.. = stainless steel- weld-on ends	
	..50.. = 3.2...63 l/min, G 1½ ..55.. = 5.0...100 l/min, G 1½	..A.. = without ¹⁾ ..K.. = PVC-glue connection ..E.. = stainless steel- weld-on ends	
	..60.. = 8...160 l/min, G 2 ..65.. = 16...320 l/min, G 2	..A.. = without ¹⁾ ..K.. = PVC-glue connection ..E.. = stainless steel- weld-on ends	
	..80.. = 25...500 l/min, G 2 ¾ ..85.. = 35...700 l/min, G 2 ¾	..A.. = without ¹⁾ ..K.. = PVC-glue connection ..E.. = stainless steel- weld-on ends	

¹⁾ Incl. frontal gaskets (2 pc. o-rings)

²⁾ Please specify frequency at full scale in clear text while ordering

³⁾ Please specify cable length in clear text

⁴⁾ Please specify flow direction in clear text

Weight Sensor

Model	PPS	PVDF
MIK-...08/10/15 (½")	approx. 180 g	approx. 210 g
MIK-...20/25 (¾")	approx. 190 g	approx. 225 g
MIK-...30/35 (1")	approx. 270 g	approx. 325 g
MIK-...50/55 (1 ½")	approx. 410 g	approx. 500 g
MIK-...60/65 (2")	approx. 560 g	approx. 610 g
MIK-...80/85 (2 ¾")	approx. 1200 g	approx. 1370 g

Weight Electronics

Model	Weight
MIK-...F3x0 MIK-...S30x MIK-...Lxx3	approx. 80 g
MIK-...C3xx	approx. 300
MIK-...Exxx MIK-...Gxxx	approx. 250 g

Total weight = weight sensor + weight electronics

Dimensions [mm]

Model	G	L1	L2	L3	L4	L5	L6	H1	H2
MIK-xxx08A MIK-xxx10A MIK-xxx15A	G 1/2	118	90	14	46	58	36	43	28
MIK-xxx20A MIK-xxx25A	G 3/4	122	90	16	46	58	36	43	28
MIK-xxx30A MIK-xxx35A	G 1	126	90	18	46	58	36	49.5	29.5
MIK-xxx50A MIK-xxx55A	G 1 1/2	134	90	22	68	80	36	66	31.5
MIK-xxx60A MIK-xxx65A	G 2	138	90	24	68	80	36	72	36
MIK-xxx80A MIK-xxx85A	G 2 3/4	202	150	26	96	110	75	104	52

MIK-...F3x0, MIK-...S30x, MIK-...L3x3

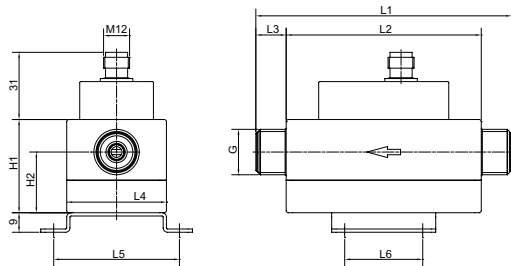

MIK-...L443

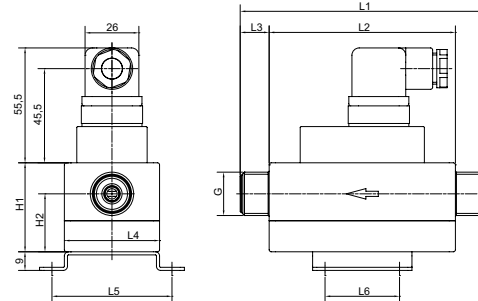

MIK-...C3xx

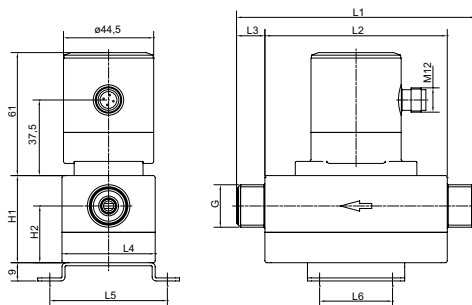

MIK-...Ex4R, MIK-...Gx4R

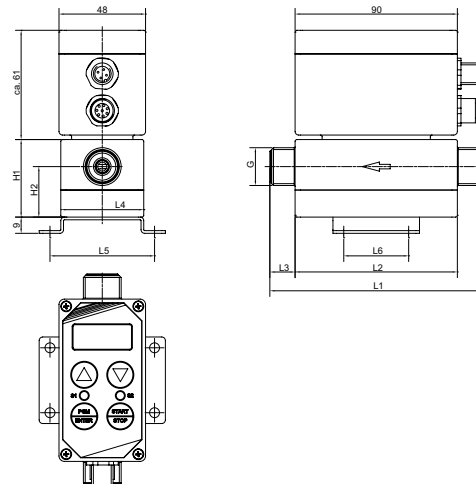

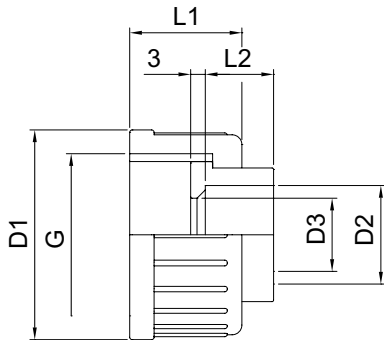

Dimensions connection set PVC-glue connection

G	D1	D2	D3	L1	L2
G 1/2	not available				
G 3/4	Ø 35	Ø 16	Ø 10.5	21	14
G 1	Ø 43	Ø 20	Ø 15	23	16
G 1 1/2	Ø 60	Ø 32	Ø 26	27	22
G 2	Ø 74	Ø 40	Ø 33	30	26
G 2 3/4	Ø 103	Ø 63	Ø 54	38	38

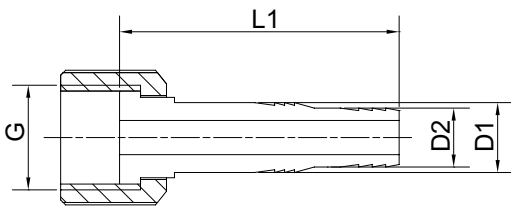

Dimensions connection set PVC-hose connection

G	D1	D2	L
G 1/2	Ø 14	Ø 12	56
G 3/4	Ø 18	Ø 16	60
G 1	Ø 22	Ø 20	67
G 1 1/2	not available		
G 2	not available		
G 2 3/4	not available		

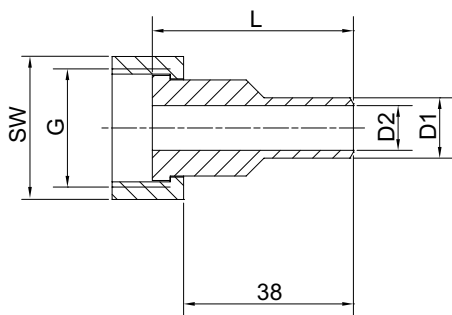

Dimensions connection set stainless steel weld-on ends

G	SW	L	D1	D2
G 1/2	24	45	Ø 10.2	Ø 5
G 3/4	32	45	Ø 13.5	Ø 10
G 1	41	45	Ø 19	Ø 15
G 1 1/2	55	60	Ø 25	Ø 20
G 2	70	60	Ø 38	Ø 32
G 2 3/4	90	60	Ø 60.3	Ø 54