



QS200 INSERTION ULTRASONIC FLOWMETER SADDLE FOR LARGE PIPE SIZES

The 6, 8, 10, and 12 inch saddles are designed exclusively for the QS200 Insertion Ultrasonic Flowmeter. Supporting commercial and agricultural irrigation applications on large size pipes, the QS200 will accurately provide the information your controller needs to display the flow rate and accumulated total.

FEATURES / BENEFITS

- Low-cost, effective and easy installation
- No moving mechanical parts (low-maintenance)
- Simple two-wire connector (for power and pulse)
- Compatible with irrigation controllers (common name brands)
- High accuracy: $\pm 2.0\%$ of reading (compared to full scale accuracy)
- Provides extended leak detection down to 0.1 fps (0.03 m/s)
- LED light indicators: (green for power and amber for pulse)
- Patented design
- Ideal for clean water flow measurement
- External wiring: (direct burial wire)

SPECIFICATIONS

Insert Wetted Materials:	Body: PPS (Ryton R-4)
	Sensor: PEI (Ultem 1000)
	O-Ring: EPDM
Temperature Rating:	
Operating:	32° F to 140° F (0° C to 60° C)
Storage:	-20° F to +160° F (-29° C to +71° C)
Flow Range:	0.1 to 15 fps (0.03 to 4.6 m/s)
Accuracy:	Typically $\pm 2\%$ of reading
Operating Pressure:	150 psi @ 73° F (10 bar @ 23° C) 100 psi @ 140° F (7 bar @ 60° C)
Transducer Excitation:	Supply Voltage: 7.5V (dc) min. to 36V (dc) max
	Quiescent Current: 200 μ A (typical)
Output Frequency:	0 to 100 Hz
Output Pulse Width:	4 ms
Electrical Cable for Insert Electronics:	36 inches (914.4 mm) of 18 AWG, solid copper, "Direct Burial" (UL 493 & 83)

INSERT DESCRIPTION

Designed for above and below grade applications, such as irrigation, municipal and underground monitoring where the flow rates are between 0.1 to 15 fps (0.03 to 4.6 m/s) and temperatures are below 140° F (60° C). QS200 inserts are supplied with two single conductors, 18 AWG solid copper wire leads that are 36 inches (914.4 mm) in length with UL Style 116666 direct burial insulation.

APPLICATIONS

- Sub-Metering Applications:
 - » High Rise Tenant Buildings
 - » Apartment Complex
 - » Universities
 - » Commercial Businesses
 - » Processing Facilities
- Agriculture Irrigation
- Turf / Landscape Irrigation Systems
- Micro Irrigation Systems
- Groundwater Monitoring

APPROVALS

IP68

CE



**SADDLE FAMILY
LINE-UP**

***PIPE NOT INCLUDED**

FLOW INSERT/SADDLE SELECTION CHART

Flowmeter Model	Description	Operating Range (Min.)	Operating Range (Max.)	Maximum Water Pressure**	Meter Material	Gasket Material	Saddle Material	Clamp Material
146090-01	6 in. (ASME pipe) w/ sensor	.1 ft/sec (9 GPM)*	15 ft/sec (1350 GPM)*	150 PSI @ 73°F (10 bar @ 23°C)	Ryton	Silicone	Aluminum	Stainless Steel
146090-02	8 in. (ASME pipe) w/ sensor	.1 ft/sec (15 GPM)*	15 ft/sec (2300 GPM)*	150 PSI @ 73°F (10 bar @ 23°C)	Ryton	Silicone	Aluminum	Stainless Steel
146090-03	10 in. (ASME pipe) w/ sensor	.1 ft/sec (24 GPM)*	15 ft/sec (3650 GPM)*	150 PSI @ 73°F (10 bar @ 23°C)	Ryton	Silicone	Aluminum	Stainless Steel
146090-04	12 in. (ASME pipe) w/ sensor	.1 ft/sec (35 GPM)*	15 ft/sec (5300 GPM)*	150 PSI @ 73°F (10 bar @ 23°C)	Ryton	Silicone	Aluminum	Stainless Steel
146090-05	6 in. (Tube) w/ sensor	.1 ft/sec (8 GPM)*	15 ft/sec (1230 GPM)*	150 PSI @ 73°F (10 bar @ 23°C)	Ryton	Silicone	Aluminum	Stainless Steel
146090-06	8 in. (Tube) w/ sensor	.1 ft/sec (15 GPM)*	15 ft/sec (2200 GPM)*	150 PSI @ 73°F (10 bar @ 23°C)	Ryton	Silicone	Aluminum	Stainless Steel
146090-07	10 in. (Tube) w/ sensor	.1 ft/sec (23 GPM)*	15 ft/sec (3500 GPM)*	150 PSI @ 73°F (10 bar @ 23°C)	Ryton	Silicone	Aluminum	Stainless Steel
146090-08	12 in. (Tube) w/ sensor	.1 ft/sec (85 GPM)*	15 ft/sec (5100 GPM)*	150 PSI @ 73°F (10 bar @ 23°C)	Ryton	Silicone	Aluminum	Stainless Steel
Saddle Only Model	Description	Operating Range (Min.)	Operating Range (Max.)	Maximum Water Pressure**	Meter Material	Gasket Material	Saddle Material	Clamp Material
146080-01	6 in. (ASME pipe)	N/A	N/A	150 PSI @ 73°F (10 bar @ 23°C)	N/A	Silicone	Aluminum	Stainless Steel
146080-02	8 in. (ASME pipe)	N/A	N/A	150 PSI @ 73°F (10 bar @ 23°C)	N/A	Silicone	Aluminum	Stainless Steel
146080-03	10 in. (ASME pipe)	N/A	N/A	150 PSI @ 73°F (10 bar @ 23°C)	N/A	Silicone	Aluminum	Stainless Steel
146080-04	12 in. (ASME pipe)	N/A	N/A	150 PSI @ 73°F (10 bar @ 23°C)	N/A	Silicone	Aluminum	Stainless Steel
146080-05	6 in. (Tube)	N/A	N/A	150 PSI @ 73°F (10 bar @ 23°C)	N/A	Silicone	Aluminum	Stainless Steel
146080-06	8 in. (Tube)	N/A	N/A	150 PSI @ 73°F (10 bar @ 23°C)	N/A	Silicone	Aluminum	Stainless Steel
146080-07	10 in. (Tube)	N/A	N/A	150 PSI @ 73°F (10 bar @ 23°C)	N/A	Silicone	Aluminum	Stainless Steel
146080-08	12 in. (Tube)	N/A	N/A	150 PSI @ 73°F (10 bar @ 23°C)	N/A	Silicone	Aluminum	Stainless Steel

*Nominal flow rate shown. Actual flow is dependent on pipe schedule (wall thickness).

** Maximum water pressure for larger line sizes would be based on the material of the sensor, adapter, and pipe. Pressure is also derated due to temperature (1.20 psi / °F).

DIMENSIONS

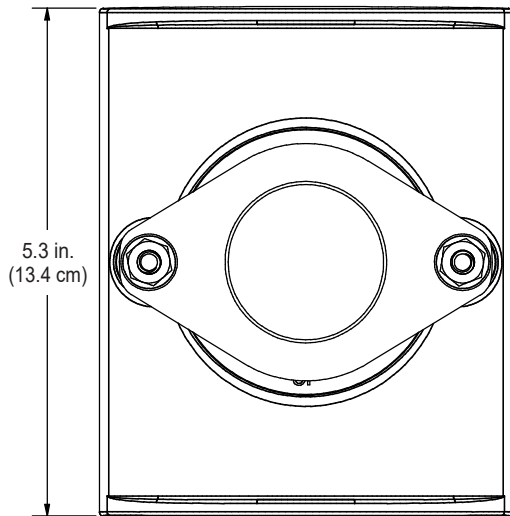

SADDLE - TOP VIEW

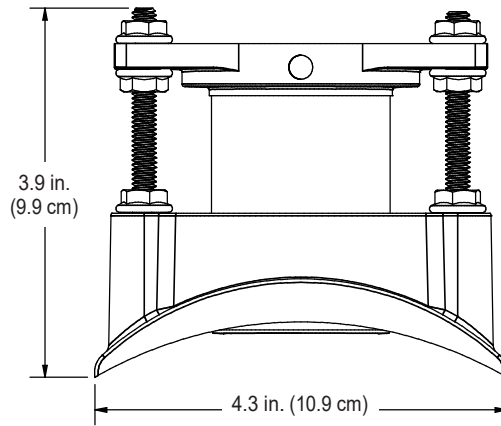

SADDLE - FRONT VIEW

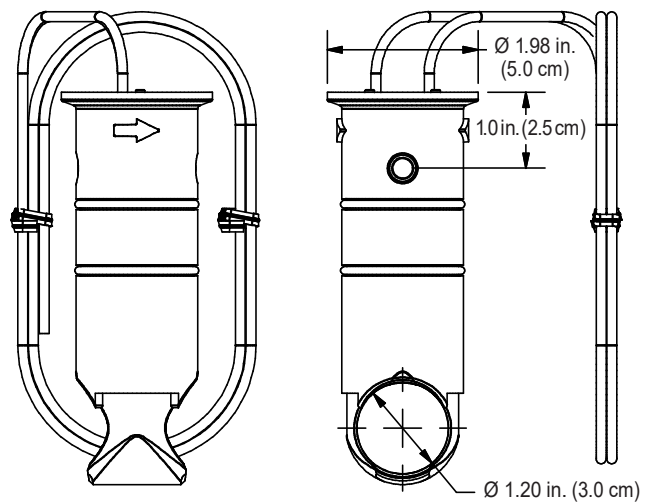

QS200 INSERT

K-FACTORS

K-Value Formula (Turf Controller) = 60 / K-Factor

K-Factors for 6 in. Fluid Lines							
6 in. Fluid Lines							
----- TUBE 11GA = 3.698 -----							
----- Sch 80 = 3.684 -----							
----- Class 200 = 3.403 -----							
----- Sch 40 = 3.316 -----							
----- Sch 10 = 2.962 -----							
5.70 in. (14.4 cm)	5.80 in. (14.7 cm)	5.90 in. (15.0 cm)	6.0 in. (15.2 cm)	6.10 in. (15.5 cm)	6.20 in. (15.7 cm)	6.30 in. (16.0 cm)	6.40 in. (16.2 cm)
Inside Diameter							

K-FACTORS CONTINUED

