



# QS200 Saddle

Insertion Ultrasonic Flowmeter Options  
for Large Pipe Sizes

---

**LINE SIZES:** 6 in., 8 in., 10 in., 12 in. (Tube, Pipe)

---

U.S. Design Patent No. D845,804 - Ultrasonic Insert

*Please save these instructions for future reference. Read carefully before attempting to assemble, install, operate or maintain the product described.*

*Protect yourself and others by observing all safety information. Failure to comply with instructions could result in personal injury and/or property damage.*

*Please refer to back cover for information regarding this product's warranty and other important information.*

*If you are missing parts, or experience problems with your installation, contact our Customer Support Department. We will be happy to assist you.*

**Call: 888-996-3837 or 316-686-7361**

**Email: [meters@gplains.com](mailto:meters@gplains.com)**

**SAVE FOR YOUR RECORDS**

**Model #:** \_\_\_\_\_

**Serial #:** \_\_\_\_\_

**Purch. Date:** \_\_\_\_\_

## UNPACKING



### Contents:

920913-01 Quick Start Guide (QS200 Saddle)	(1) Sleeve
(1) Saddle (sized specifically for your pipe O.D.)	(1) Gasket
(2) Band Clamps	Hardware
(1) Retention Pin (Quick Release)	(1) Sensor (if ordered)
(1) Sensor Owners Manual	



### Inspect

- After unpacking the unit, inspect carefully for any damage that may have occurred during transit. Check for loose, missing or damaged parts. Shipping damage claims must be filed with carrier.
- See General Safety Instructions, and all Cautions, Warnings, and Dangers as shown.



To do a complete and successful installation, you must carefully read this manual and the manual for the sensor.

## BEFORE CUTTING A HOLE IN THE PIPE

- Verify you have all the pieces.
- Verify this saddle size is the same as your pipe outside diameter.
- Verify the pipe is not pressurized.
- Verify the desired hole location is more than 10 diameters downstream and 5 diameters upstream from any obstructions. Valves, pumps, elbows, reducers are all considered obstructions.
- Note that the finished hole diameter should be between 1-15/16" to 2". It should be clean and free of burrs.
- We recommend the hole be made with a hole saw.
- Note the direction of flow. Measuring water only.

### Tools and Materials Needed

- Ø1-15/16" to Ø2.0" hole saw and drill
- 7/16" end wrenches
- Tape measure
- Permanent marker



## GENERAL SAFETY INSTRUCTIONS

**IMPORTANT:** It is your responsibility to:

- Ensure that all equipment operators have access to adequate instructions concerning safe operating and maintenance procedures.

**⚠ CAUTION** *This product is not approved for use with petroleum products (diesel fuel, unleaded gasoline, jet fuel, kerosene, etc.), aromatic hydrocarbons or other incompatible chemicals*

**⚠ CAUTION** *This product is not approved for use in hazardous locations.*

**⚠ WARNING** *When applying power, adhere to specifications listed in appropriate electronics manual.*

**⚠ CAUTION** *Disconnect external power before attaching or detaching input or output wires.*

NOTE: Be sure O-rings and seals are kept in good repair.

**⚠ WARNING** *Compatibility of this product's material and the process fluid and/or environment should be considered prior to putting into service.*

**⚠ WARNING** *Product should never be operated outside its published specifications for temperature or pressure. See specifications for your model.*

**⚠ WARNING** *Make sure flow and pressure have been eliminated from process pipe prior to installing or removing product.*

**⚠ CAUTION** *Installation near high electromagnetic fields and high current fields is not recommended and may result in inaccurate readings.*

**⚠ CAUTION** *Do not allow water to freeze in meter. Ice expansion may burst the plastic housing.*

**⚠ CAUTION** *Do not allow this meter to be used with steam.*

**⚠ CAUTION** *Thermal expansion/contraction of plastic pipe can cause clamps to loosen. Make sure clamps are ALWAYS tight (Recommended Torque is 75 IN·LB).*

## FLOW INSERT/SADDLE SELECTION CHART

Flowmeter Model	Description	Operating Range (Min.)	Operating Range (Max.)	Maximum Water Pressure**	Meter Material	Gasket Material	Saddle Material	Clamp Material
146080-01	6 in. (ASME pipe)	.1 ft/sec (9 GPM)*	15 ft/sec (1350 GPM)*	150 PSI @ 73°F (10 bar @ 23°C)	N/A	Silicone	Anodized Aluminum	Stainless Steel
146080-02	8 in. (ASME pipe)	.1 ft/sec (15 GPM)*	15 ft/sec (2300 GPM)*	150 PSI @ 73°F (10 bar @ 23°C)	N/A	Silicone	Anodized Aluminum	Stainless Steel
146080-03	10 in. (ASME pipe)	.1 ft/sec (24 GPM)*	15 ft/sec (3650 GPM)*	150 PSI @ 73°F (10 bar @ 23°C)	N/A	Silicone	Anodized Aluminum	Stainless Steel
146080-04	12 in. (ASME pipe)	.1 ft/sec (35 GPM)*	15 ft/sec (5300 GPM)*	150 PSI @ 73°F (10 bar @ 23°C)	N/A	Silicone	Anodized Aluminum	Stainless Steel
146080-05	6 in. (Tube)	.1 ft/sec (8 GPM)*	15 ft/sec (1230 GPM)*	150 PSI @ 73°F (10 bar @ 23°C)	N/A	Silicone	Anodized Aluminum	Stainless Steel
146080-06	8 in. (Tube)	.1 ft/sec (15 GPM)*	15 ft/sec (2200 GPM)*	150 PSI @ 73°F (10 bar @ 23°C)	N/A	Silicone	Anodized Aluminum	Stainless Steel
146080-07	10 in. (Tube)	.1 ft/sec (23 GPM)*	15 ft/sec (3500 GPM)*	150 PSI @ 73°F (10 bar @ 23°C)	N/A	Silicone	Anodized Aluminum	Stainless Steel
146080-08	12 in. (Tube)	.1 ft/sec (85 GPM)*	15 ft/sec (5100 GPM)*	150 PSI @ 73°F (10 bar @ 23°C)	N/A	Silicone	Anodized Aluminum	Stainless Steel
146090-01	6 in. (ASME pipe) w/ sensor	.1 ft/sec (9 GPM)*	15 ft/sec (1350 GPM)*	150 PSI @ 73°F (10 bar @ 23°C)	Ryton	Silicone	Anodized Aluminum	Stainless Steel
146090-02	8 in. (ASME pipe) w/ sensor	.1 ft/sec (15 GPM)*	15 ft/sec (2300 GPM)*	150 PSI @ 73°F (10 bar @ 23°C)	Ryton	Silicone	Anodized Aluminum	Stainless Steel
146090-03	10 in. (ASME pipe) w/ sensor	.1 ft/sec (24 GPM)*	15 ft/sec (3650 GPM)*	150 PSI @ 73°F (10 bar @ 23°C)	Ryton	Silicone	Anodized Aluminum	Stainless Steel
146090-04	12 in. (ASME pipe) w/ sensor	.1 ft/sec (35 GPM)*	15 ft/sec (5300 GPM)*	150 PSI @ 73°F (10 bar @ 23°C)	Ryton	Silicone	Anodized Aluminum	Stainless Steel
146090-05	6 in. (Tube) w/ sensor	.1 ft/sec (8 GPM)*	15 ft/sec (1230 GPM)*	150 PSI @ 73°F (10 bar @ 23°C)	Ryton	Silicone	Anodized Aluminum	Stainless Steel
146090-06	8 in. (Tube) w/ sensor	.1 ft/sec (15 GPM)*	15 ft/sec (2200 GPM)*	150 PSI @ 73°F (10 bar @ 23°C)	Ryton	Silicone	Anodized Aluminum	Stainless Steel
146090-07	10 in. (Tube) w/ sensor	.1 ft/sec (23 GPM)*	15 ft/sec (3500 GPM)*	150 PSI @ 73°F (10 bar @ 23°C)	Ryton	Silicone	Anodized Aluminum	Stainless Steel
146090-08	12 in. (Tube) w/ sensor	.1 ft/sec (85 GPM)*	15 ft/sec (5100 GPM)*	150 PSI @ 73°F (10 bar @ 23°C)	Ryton	Silicone	Anodized Aluminum	Stainless Steel

\*Nominal flow rate shown. Actual flow is dependent on pipe schedule (wall thickness).

\*\* Maximum water pressure for larger line sizes would be based on the material of the sensor, adapter, and pipe. Pressure is also derated due to temperature (1.20 psi / °F).

**SPECIFICATIONS (CONTINUED)**

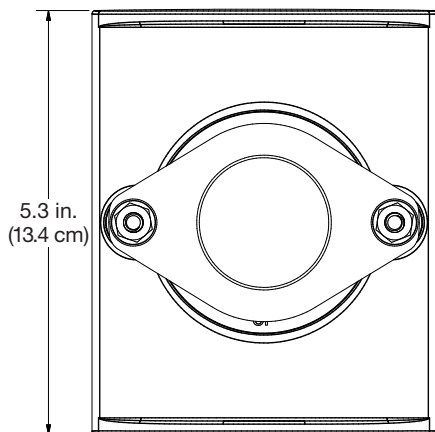

**SADDLE - TOP VIEW**

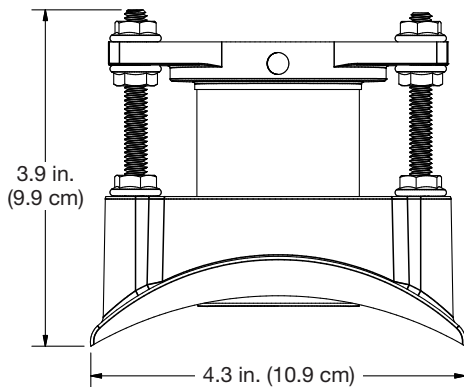

**SADDLE - FRONT VIEW**

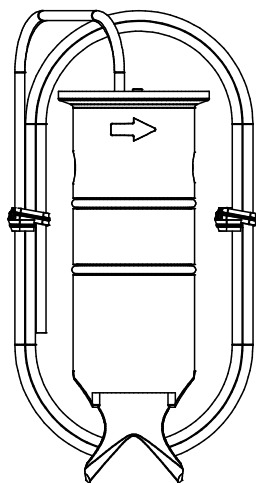

**QS200 INSERT**

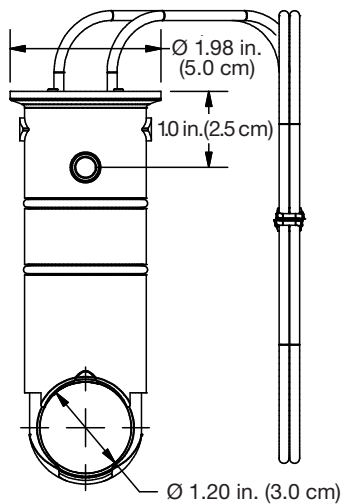

## INSTALLATION

### Step 1 – Drilling hole:

It is recommended that the saddle/sensor not be located on the very top or very bottom of the pipe. Ideal performance can be achieved with the saddle mounted at 2 to 4 o'clock or 8 to 10 o'clock. Hole should also be drilled perpendicular to the pipe centerline and tangent to the curvature.

### Step 2 – Mounting the saddle:

The saddle will need to be preassembled to insure the fit is proper. Assemble the hardware as shown in Figure 1. Tighten only the bottom nuts that hold the threaded studs to the saddle.

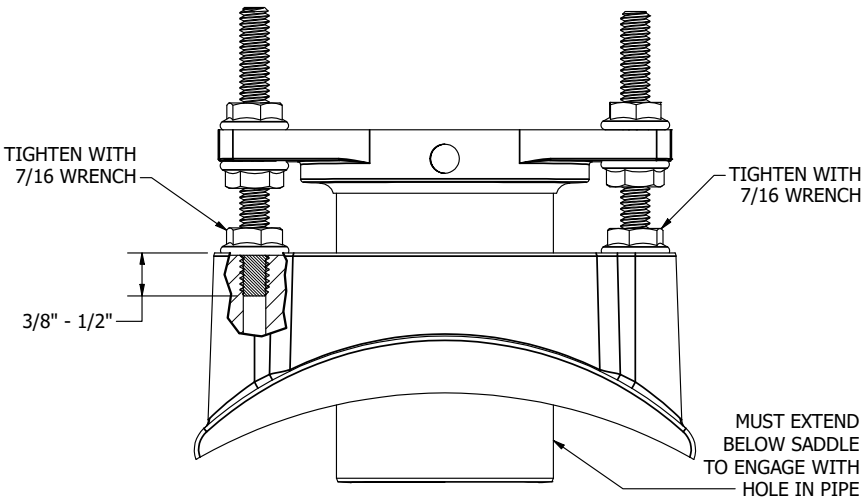

**Figure 1**

Place gasket over hole in pipe, place pre-assembled saddle from above over gasket. Be sure saddle engages hole properly and saddle contour matches pipe's outside diameter. Attach 2 each band clamps as shown in Figure 2 and tighten with 7/16 inch wrench. Recommended Torque is 75 IN•LB.

**NOTE:** Clamps can loosen when mounted to plastic pipe, due to thermal contraction.

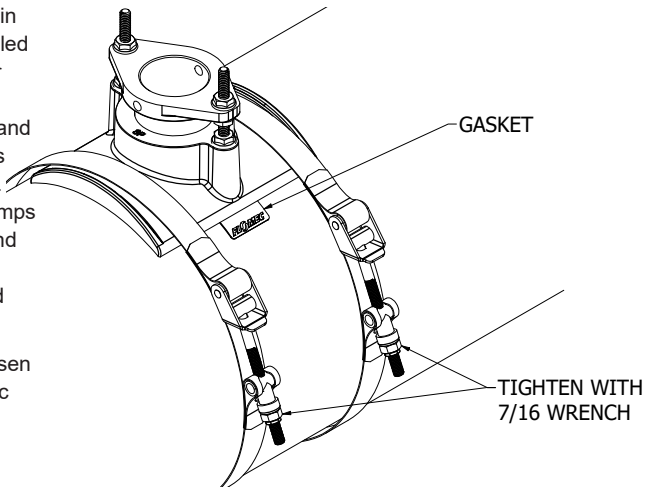

**Figure 2**

## INSTALLATION (CONTINUED)

### Step 3 – Mounting the Sleeve:

Remove the top two nuts and pull sleeve from saddle. Using a tape measure, measure the distance from the lip of the inside of pipe to the top of the saddle. Reference the asterisk in Figure 3.

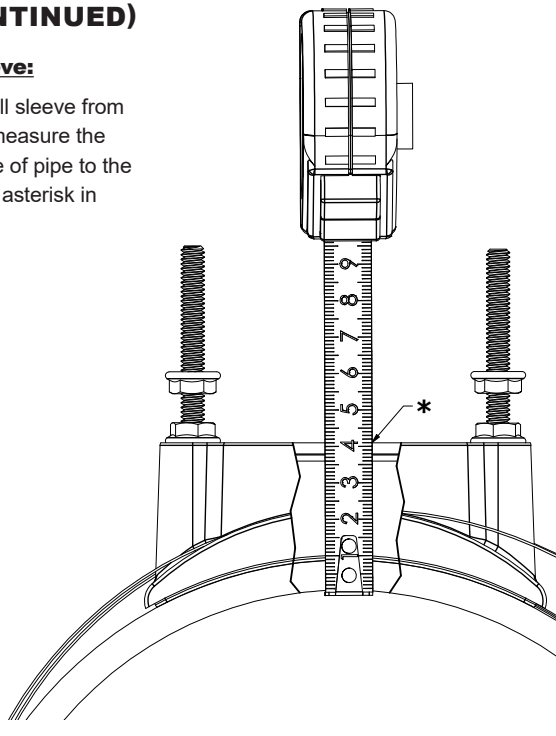

Figure 3

Transpose this measurement onto the sleeve as shown in Figure 4 and mark with a permanent marker.

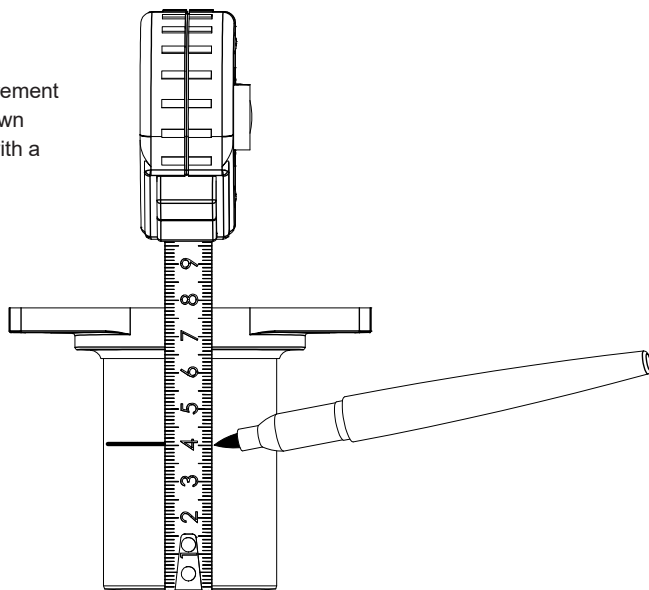
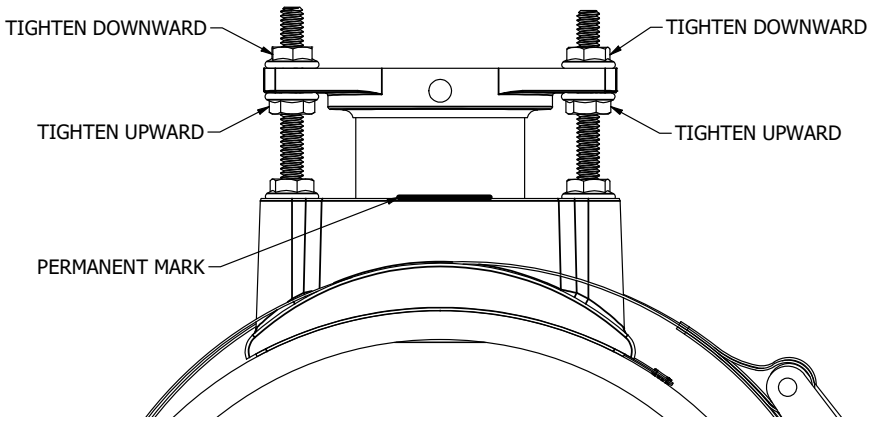

Figure 4



**INSTALLATION (CONTINUED)**

Place the marked sleeve back into saddle, engaging the threaded studs to the depth marked. Twist the bottom nuts upward to bottom of sleeve flange, replace the two nuts removed earlier and tighten all nuts with 7/16 wrench. See Figure 5.



**Figure 5**

**Step 4 – Mounting the Sensor:**

Note the flow arrows on the side of the sensor, these must point downstream. Insert sensor into sleeve, press down until hole in sensor matches hole in sleeve. Insert retention pin. Final sensor depth should match that shown in Figure 6.

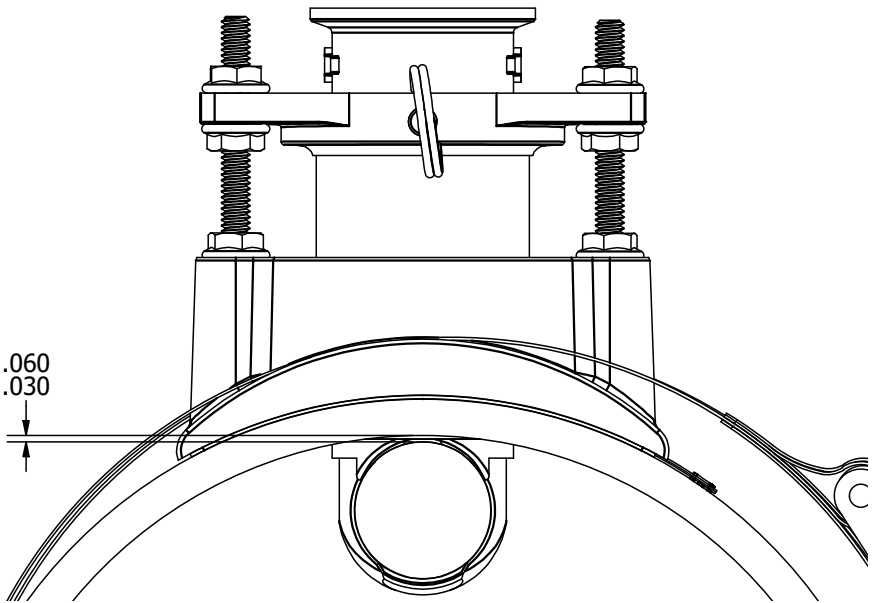

**Figure 6**

**Determining the K-factor:**

The K-factor value is needed to convert the sensor's output pulsed into volume or rate data. The graphs located on the back of the Quick Start Guide show K-factor values for many versions of water lines. By knowing the line you're using or the inside diameter of the line, you can determine this value.

The values on the graphs are indicated in Pulses per Gallon. Some controllers and register equipment want this value in terms of frequency. When this is the case, divide 60 by the K-factor (see following pages for these values).

Example: (8-inch Sch40 = 1.838 Pulses per Gallon)  $60 / 1.838 = 32.644$

Many of K-factor values shown in the graphs were theoretically generated from actual lab test data. Because of this, these graphs are for reference only, actual system accuracy should always be verified if possible.

# OPERATION (CONTINUED)

## K-FACTOR FREQUENCY VALUES

NOMINAL SIZE	MATERIAL	CLASSIFICATION	PRESSURE psi	OUTSIDE DIA. inches	WALL THICKNESS inches	INSIDE DIA. inches	CIRCUMFERENCE		Reference		Typical Irrigation K-Value	Rainmaster Value
							inches	inches	K-factor pulses/gal	liters		
6"	HDPE	GEO THERMAL (SDR 9)		6.625	0.736	5.153	20.813	1.168	4.420	13.575	3702	
6"	TUBE (STEEL)	7 GA		6.000	0.188	5.624	18.850	3.850	1.017	15.585	4251	
6"	TUBE (STEEL)	10 GA		6.000	0.135	5.730	18.850	3.722	0.983	16.122	4397	
6"	TUBE (STEEL)	11 GA		6.000	0.125	5.750	18.850	3.698	0.977	16.225	4425	
6"	PIPE (ALUM)	SCH80		6.625	0.432	6.684	20.813	3.684	0.973	16.287	4442	
6"	PVC	SCH80	167	6.625	0.432	5.761	20.813	3.684	0.973	16.287	4442	
6"	125# PVC	PIP (SDR 32.5)	125	6.140	0.189	5.762	19.289	3.683	0.973	16.292	4443	
6"	TUBE (STEEL)	12 GA		6.000	0.105	5.790	18.850	3.649	0.964	16.443	4485	
6"	TUBE (ALUM)	IRRIGATION PIPE		6.000	0.083	5.834	18.850	3.596	0.950	16.687	4551	
6"	TUBE (STEEL)	14 GA		6.000	0.083	5.834	18.850	3.596	0.950	16.687	4551	
6"	100# PVC	PIP (SDR 41)	100	6.140	0.150	5.840	19.289	3.588	0.948	16.721	4560	
6"	TUBE (ALUM)	IRRIGATION PIPE		6.000	0.058	5.884	18.850	3.535	0.934	16.973	4629	
6"	TUBE (ALUM)	IRRIGATION PIPE		6.000	0.051	5.898	18.850	3.518	0.929	17.054	4651	
6"	80# PVC	PIP (SDR 51)	80	6.140	0.121	5.898	19.289	3.518	0.929	17.054	4651	
6"	50# PVC	PIP (SDR 81)	50	6.140	0.076	5.988	19.289	3.409	0.901	17.599	4800	
6"	200# PVC	IPS (SDR 21) CL 200	200	6.625	0.316	5.993	20.813	3.403	0.899	17.631	4808	
6"	LH PVC	PIP (SDR 91)	91	6.140	0.070	6.000	19.289	3.395	0.897	17.675	4820	
6"	HDPE	DR 11.5	125	7.119	0.527	6.065	22.365	3.316	0.876	18.094	4935	
6"	PIPE (ALUM)	SCH40		6.625	0.280	6.065	20.813	3.316	0.876	18.094	4935	
6"	PVC	SCH40	106	6.625	0.280	6.065	20.813	3.316	0.876	18.094	4935	
6"	HDPE	DR 15	100	6.873	0.404	6.065	21.592	3.316	0.876	18.094	4935	
6"	HDPE	DR 19	80	6.703	0.319	6.065	21.058	3.316	0.876	18.094	4935	
6"	160# PVC	IPS (SDR 26) CL 160	160	6.625	0.255	6.115	20.813	3.255	0.860	18.430	5027	
6"	125# PVC	IPS (SDR 32.5) CL 125	125	6.625	0.204	6.217	20.813	3.132	0.827	19.157	5225	
6"	PIPE (STEEL)	7 GA		6.625	0.188	6.249	20.813	3.093	0.817	19.397	5290	
6"	100# PVC	CL 100	100	6.625	0.162	6.301	20.813	3.000	0.801	19.800	5400	
6"	PIPE (STEEL)	10 GA		6.625	0.135	6.355	20.813	2.965	0.783	20.236	5519	
6"	PIPE (ALUM)	SCH10		6.625	0.134	6.357	20.813	2.963	0.783	20.253	5524	
6"	PIPE (STEEL)	12 GA		6.625	0.105	6.415	20.813	2.892	0.764	20.744	5658	
6"	63# PVC	IPS (SDR 63) CL 63	63	6.625	0.104	6.417	20.813	2.890	0.763	20.762	5662	

# OPERATION (CONTINUED)

## K-FACTOR FREQUENCY VALUES

NOMINAL SIZE	MATERIAL	CLASSIFICATION	PRESSURE psi	OUTSIDE DIA.		WALL THICKNESS inches	INSIDE DIA. inches	CIRCUMFERENCE		Reference K-factor		Typical Irrigation K-Value	Rainmaster Value
				inches	inches			pulses/Gal	pulses/litre				
8"	HDPE	GEOHERMAL (SDR 9)		8.625	8.625	0.958	6.709	27.096	2.501	0.661	23.988	6542	
8"	HDPE	GEOHERMAL (SDR 11)		8.625	8.625	0.784	7.057	27.096	2.317	0.612	25.897	7063	
8"	TUBE (STEEL)	7 GA		8.000	8.000	0.188	7.624	25.133	2.017	0.533	29.754	8115	
8"	PIPE	SCH80		8.625	8.625	0.500	7.625	27.096	2.016	0.533	29.762	8117	
8"	PVC	SCH80	148	8.625	8.625	0.500	7.625	27.096	2.016	0.533	29.762	8117	
8"	125# PVC	PIP (SDR 32.5)	125	8.160	8.160	0.251	7.658	25.635	1.999	0.528	30.022	8188	
8"	TUBE (STEEL)	10 GA		8.000	8.000	0.135	7.730	25.133	1.960	0.518	30.606	8347	
8"	TUBE (STEEL)	11 GA		8.000	8.000	0.125	7.750	25.133	1.951	0.515	30.753	8387	
8"	100# PVC	PIP (SDR 41)	100	8.160	8.160	0.199	7.762	25.635	1.943	0.513	30.873	8420	
8"	TUBE (STEEL)	12 GA		8.000	8.000	0.105	7.790	25.133	1.929	0.509	31.111	8485	
8"	200# PVC	IPS (SDR 21) CL 200	200	8.625	8.625	0.410	7.805	27.096	1.921	0.507	31.240	8520	
8"	TUBE (ALUM)	IRRIGATION PIPE		8.000	8.000	0.090	7.820	25.133	1.913	0.505	31.369	8555	
8"	TUBE (STEEL)	14 GA		8.000	8.000	0.083	7.834	25.133	1.905	0.503	31.491	8589	
8"	80# PVC	PIP (SDR 51)	80	8.160	8.160	0.160	7.840	25.635	1.902	0.502	31.544	8603	
8"	TUBE (ALUM)	IRRIGATION PIPE		8.000	8.000	0.072	7.856	25.133	1.894	0.500	31.685	8642	
8"	TUBE (ALUM)	IRRIGATION PIPE		8.000	8.000	0.064	7.872	25.133	1.885	0.498	31.828	8680	
8"	TUBE (ALUM)	IRRIGATION PIPE		8.000	8.000	0.051	7.898	25.133	1.871	0.494	32.062	8744	
8"	50# PVC	PIP (SDR 81)	50	8.160	8.160	0.101	7.958	25.635	1.840	0.486	32.616	8895	
8"	PVC	SCH40	93	8.625	8.625	0.332	7.961	27.096	1.838	0.486	32.644	8903	
8"	160# PVC	IPS (SDR 26) CL 160	160	8.625	8.625	0.332	7.961	27.096	1.838	0.486	32.644	8903	
8"	PIPE	SCH40		8.625	8.625	0.322	7.981	27.096	1.827	0.483	32.833	8955	
8"	125# PVC	IPS (SDR 32.5) CL 125	125	8.625	8.625	0.265	8.095	27.096	1.767	0.467	33.956	9261	
8"	100# PVC	IPS (SDR 41) CL 100	100	8.625	8.625	0.210	8.205	27.096	1.709	0.451	35.114	9577	
8"	PIPE	SCH10		8.625	8.625	0.148	8.329	27.096	1.643	0.434	36.517	9959	
8"	63# PVC	IPS (SDR 64) CL 63	63	8.625	8.625	0.135	8.355	27.096	1.629	0.430	36.826	10044	

# OPERATION (CONTINUED)

## K-FACTOR FREQUENCY VALUES

NOMINAL SIZE	MATERIAL	CLASSIFICATION	PRESSURE psi	OUTSIDE DIA.		WALL THICKNESS		INSIDE DIA.		CIRCUMFERENCE		Reference K-factor		Typical Irrigation K-Value	Rainmaster Value
				inches	inches	inches	inches	inches	inches	pulses/gal	pulses/litre				
10"	HDPE	GEO THERMAL (SDR 9)		10.750	1.194	8.362		33.772		1.747	0.461	34.348	9368		
10"	HDPE	GEO THERMAL (SDR 11)		10.750	0.977	8.796		33.772		1.556	0.411	38.572	10520		
10"	PIPE	SCH80		10.750	0.593	9.564		33.772		1.217	0.321	49.302	13446		
10"	PVC	SCH80	140	10.750	0.593	9.564		33.772		1.217	0.321	49.302	13446		
10"	12.5# PVC	PIP (SDR 32.5)	125	10.200	0.314	9.572		32.044		1.213	0.321	49.445	13485		
10"	TUBE (STEEL)	7 GA		10.000	0.188	9.624		31.416		1.191	0.315	50.397	13745		
10"	100# PVC	PIP (SDR 41)	100	10.200	0.249	9.702		32.044		1.156	0.305	51.896	14153		
10"	TUBE (STEEL)	10 GA		10.000	0.135	9.730		31.416		1.144	0.302	52.455	14306		
10"	TUBE (STEEL)	11 GA		10.000	0.125	9.750		31.416		1.135	0.300	52.863	14417		
10"	200# PVC	IPS (SDR 21) CL 200	200	10.750	0.500	9.750		33.772		1.135	0.300	52.863	14417		
10"	TUBE (STEEL)	12 GA		10.000	0.105	9.790		31.416		1.117	0.295	53.697	14645		
10"	80# PVC	PIP (SDR 51)	80	10.200	0.200	9.800		32.044		1.113	0.294	53.910	14703		
10"	TUBE (ALUM)	IRRIGATION PIPE		10.000	0.094	9.812		31.416		1.108	0.293	54.167	14773		
10"	TUBE (ALUM)	IRRIGATION PIPE		10.000	0.064	9.872		31.416		1.081	0.286	55.492	15134		
10"	TUBE (ALUM)	IRRIGATION PIPE		10.000	0.051	9.898		31.416		1.070	0.283	56.087	15297		
10"	160# PVC	IPS (SDR 26) CL 160	160	10.750	0.413	9.924		33.772		1.058	0.280	56.694	15462		
10"	50# PVC	PIP (SDR 81)	50	10.200	0.126	9.948		32.044		1.048	0.277	57.267	15618		
10"	PVC	SCH40	84	10.750	0.365	10.020		33.772		1.016	0.268	59.055	16106		
10"	PIPE	SCH40		10.750	0.365	10.020		33.772		1.016	0.268	59.055	16106		
10"	12.5# PVC	IPS (SDR 32.5) CL 125	125	10.750	0.331	10.088		33.772		0.986	0.260	60.851	16596		
10"	100# PVC	IPS (SDR 41) CL 100	100	10.750	0.262	10.226		33.772		0.925	0.244	64.852	17687		
10"	63# PVC	IPS (SDR 64) CL 63	63	10.750	0.168	10.414		33.772		0.842	0.223	71.232	19427		
10"	PIPE	SCH10		10.750	0.165	10.420		33.772		0.840	0.222	71.456	19488		

# OPERATION (CONTINUED)

## K-FACTOR FREQUENCY VALUES

NOMINAL SIZE	MATERIAL	CLASSIFICATION	PRESSURE psi	OUTSIDE DIA. inches	WALL THICKNESS inches	INSIDE DIA. inches	CIRCUMFERENCE inches	Reference K-factor		Typical Irrigation K-Value	Rainmaster Value
								pulses/Gal	pulses/litre		
12"	HDPE	GEO THERMAL (SDR 9)		12.750	1.417	9.916	40.055	1.371	0.362	43.765	11936
12"	HDPE	GEO THERMAL (SDR 11)		12.750	1.159	10.432	40.055	1.215	0.321	49.390	13470
12"	PIPE	SCH80		12.750	0.687	11.376	40.055	0.929	0.245	64.574	17611
12"	PVC	SCH80	137	12.750	0.687	11.376	40.055	0.929	0.245	64.574	17611
12"	12.5# PVC	PIP (SDR 32.5)	125	12.240	0.377	11.486	38.453	0.896	0.237	66.973	18265
12"	200# PVC	IPS (SDR 21) CL 200	200	12.750	0.606	11.538	40.055	0.880	0.233	68.170	18592
12"	100# PVC	PIP (SDR 41)	100	12.240	0.299	11.642	38.453	0.849	0.224	70.698	19281
12"	TUBE (STEEL)	10 GA		12.000	0.135	11.730	37.699	0.822	0.217	72.988	19906
12"	TUBE (STEEL)	11 GA		12.000	0.125	11.750	37.699	0.816	0.216	73.529	20054
12"	80# PVC	PIP (SDR 51)	80	12.240	0.240	11.760	38.453	0.813	0.215	73.803	20128
12"	160# PVC	IPS (SDR 26) CL 160	160	12.750	0.490	11.770	40.055	0.810	0.214	74.079	20204
12"	TUBE (STEEL)	12 GA		12.000	0.105	11.790	37.699	0.804	0.212	74.637	20356
12"	TUBE (ALUM)	IRRIGATION PIPE		12.000	0.094	11.812	37.699	0.797	0.211	75.260	20526
12"	TUBE (ALUM)	IRRIGATION PIPE		12.000	0.064	11.872	37.699	0.779	0.206	77.014	21004
12"	PVC	SCH40	79	12.750	0.408	11.934	40.055	0.769	0.201	78.914	21522
12"	PIPE	SCH40		12.750	0.408	11.934	40.055	0.760	0.201	78.914	21522
12"	50# PVC	PIP (SDR 81)	50	12.240	0.151	11.938	38.453	0.759	0.201	79.040	21557
12"	12.5# PVC	IPS (SDR 32.5) CL 125	125	12.750	0.392	11.966	40.055	0.751	0.198	79.932	21800
12"	100# PVC	IPS (SDR 41) CL 100	100	12.750	0.311	12.128	40.055	0.702	0.185	85.517	23323
12"	63# PVC	IPS (SDR 64) CL 63	63	12.750	0.199	12.352	40.055	0.634	0.167	94.662	25817
12"	PIPE	SCH10		12.750	0.180	12.390	40.055	0.622	0.164	96.411	26294

## REPAIR PARTS LIST FOR QS200 SADDLE

Part Number	Description
146502-01	Kit, Saddle Gasket
146503-01	Kit, Clamps (6 Inch ASME Pipe)
146503-02	Kit, Clamps (6 Inch Tube)
146503-03	Kit, Clamps (8 Inch ASME Pipe)
146503-04	Kit, Clamps (8 Inch Tube)
146503-05	Kit, Clamps (10 Inch ASME Pipe)
146503-06	Kit, Clamps (10 Inch Tube)
146503-07	Kit, Clamps (12 Inch ASME Pipe)
146503-08	Kit, Clamps (12 Inch Tube)

## PARTS & SERVICE

For warranty consideration, parts, or other service information, please contact your local distributor. If you need further assistance, contact the GPI Customer Service Department in Wichita, Kansas, during normal business hours.

A toll free number is provided for your convenience.

**1-888-996-3837**

To obtain prompt, efficient service, always be prepared with the following information:

- The model number of your meter.
- The serial number or manufacturing date code of your meter.
- Part descriptions and numbers.

For warranty work, always be prepared with your original sales slip or other evidence of purchase date.

**IMPORTANT:** Please contact GPI before returning any parts. It may be possible to diagnose the trouble and identify needed parts in a telephone call.

## **FLOMEC® TWO-YEAR LIMITED WARRANTY**

Great Plains Industries, Inc. 5252 E. 36<sup>th</sup> Street North, Wichita, KS USA 67220-3205, hereby provides a limited warranty against defects in material and workmanship on all products manufactured by Great Plains Industries, Inc. This product includes a 2 year warranty. Manufacturer's sole obligation under the foregoing warranties will be limited to either, at Manufacturer's option, replacing or repairing defective Goods (subject to limitations hereinafter provided) or refunding the purchase price for such Goods theretofore paid by the Buyer, and Buyer's exclusive remedy for breach of any such warranties will be enforcement of such obligations of Manufacturer. The warranty shall extend to the purchaser of this product and to any person to whom such product is transferred during the warranty period.

The warranty period shall begin on the date of manufacture or on the date of purchase with an original sales receipt. This warranty shall not apply if:

- A. the product has been altered or modified outside the warrantor's duly appointed representative;
- B. the product has been subjected to neglect, misuse, abuse or damage or has been installed or operated other than in accordance with the manufacturer's operating instructions.

To make a claim against this warranty, contact the GPI Customer Service Department at

**316-686-7361 or 888-996-3837.**

**Or by mail at:**

**Great Plains Industries, Inc.**

**5252 E. 36th St. North**

**Wichita, KS, USA 67220-3205**

The company will step you through a product troubleshooting process to determine appropriate corrective actions.

**GREAT PLAINS INDUSTRIES, INC., EXCLUDES LIABILITY UNDER THIS WARRANTY FOR DIRECT, INDIRECT, INCIDENTAL AND CONSEQUENTIAL DAMAGES INCURRED IN THE USE OR LOSS OF USE OF THE PRODUCT WARRANTED HEREUNDER.**

The company herewith expressly disclaims any warranty of merchantability or fitness for any particular purpose other than for which it was designed.

This warranty gives you specific rights and you may also have other rights which vary from U.S. state to U.S. state.

Note: In compliance with MAGNUSON MOSS CONSUMER WARRANTY ACT – Part 702 (governs the resale availability of the warranty terms).

**IP68**



Certified to  
NSF/ANSI 61-G & 372

Wichita · Sydney

**GREAT PLAINS INDUSTRIES**



© 2020 Great Plains Industries, Inc., All Rights Reserved.

**Great Plains Industries, Inc. / 888-996-3837 / FLOMEC.net**